

## TB/TRA Series

### Speciality Temperature Sensors

#### Product Overview

The TB Series temperature sensor is designed to strap onto a pipe. The copper sensing plate provides a secondary measurement of the temperature inside the pipe. The TRA Series temperature sensor is designed for remote sensing applications. Both devices have output options compatible with building control systems and both are warranted to meet accuracy specifications for a period of five years.

#### NOTICE

- This product is not intended for life or safety applications.
- Do not install this product in hazardous or classified locations.
- Read and understand the instructions before installing this product.
- Turn off all power supplying equipment before working on it.
- The installer is responsible for conformance to all applicable codes.

No responsibility is assumed by Veris Industries for any consequences arising out of the use of this material.

#### Product Identification

Bracket Diameter	Sensor Type	Cal Certificate
TB <input type="checkbox"/>	<input type="checkbox"/>	<input type="checkbox"/>
A = 2 1/2" (6.4 cm) max. D = 8" (20 cm) max. E = 12" (31 cm) max.	B = 100R platinum, RTD C = 1k platinum, RTD D = 10k T2, Thermistor E = 2.2k, Thermistor F = 3k, Thermistor G = 10k CPC, Thermistor H = 10k T3, Thermistor I = 1k Balco (Nickel-iron) RTD J = 10k Dale, Thermistor K = 10k w/11k shunt, Thermistor	M = 20k NTC, Thermistor N = 1800 ohm, Thermistor R = 10k US, Thermistor S = 10k 3A 221, Thermistor T = 100k, Thermistor U = 20k "D", Thermistor W = 10k T2 high accuracy, Thermistor Y = 10k T3 high accuracy, Thermistor Z = 10k E1, Thermistor CC = 15k, Thermistor

Sensor Type	Cal Certificate	Cable Length
TRA <input type="checkbox"/>	<input type="checkbox"/>	<input type="checkbox"/>
B = 100R platinum, RTD C = 1k platinum, RTD D = 10k T2, Thermistor E = 2.2k, Thermistor F = 3k, Thermistor G = 10k CPC, Thermistor H = 10k T3, Thermistor I = 1k Balco (Nickel-iron) RTD J = 10k Dale, Thermistor K = 10k w/11k shunt, Thermistor	M = 20k NTC, Thermistor N = 1800 ohm, Thermistor R = 10k US, Thermistor S = 10k 3A 221, Thermistor T = 100k, Thermistor U = 20k "D", Thermistor W = 10k T2 high accuracy, Thermistor Y = 10k T3 high accuracy, Thermistor Z = 10k E1, Thermistor CC = 15k, Thermistor	None = 3 ft (0.9 m) A = 6 ft (1.8 m)* B = 10 ft (3.1 m)* C = 20 ft (6.1 m)** D = 25 ft (7.6 m)** E = 50 ft (15 m)** F = 100 ft (30 m)**

\* Not available for sensor types B, C, & I.  
\*\* Not available for sensor types B, C, E, F, I, & N.

#### Specifications

<b>Wiring</b>	22 AWG; 2-wire RTD/Thermistor
---------------	-------------------------------

## Dimensions

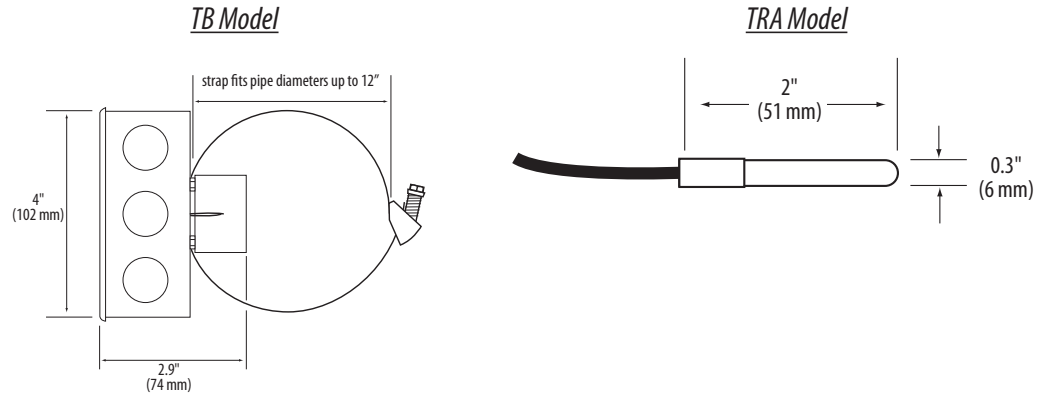

## Installation

### TB:

1. Clamp the sensor around the pipe to be monitored. Make sure the copper sensing plate is in contact with the pipe surface.
2. Wire the sensor to the controller as shown.

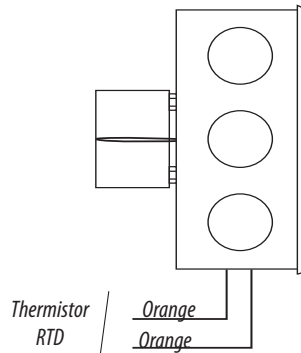

### TRA:

1. Set the stainless steel sensing probe in contact with the area to be monitored. No mounting necessary.
2. Wire the sensor to the controller as shown.

